

KARE TİP MUZ YOLLUK SİSTEMİ

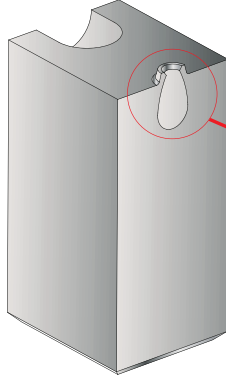

• Malzeme : 1.3343



Yüksek dayanıklı M2

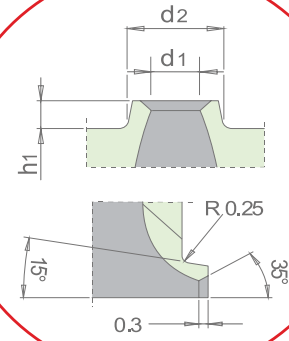

Takkeli Model

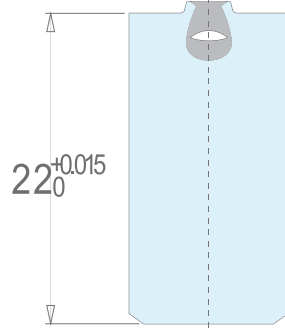
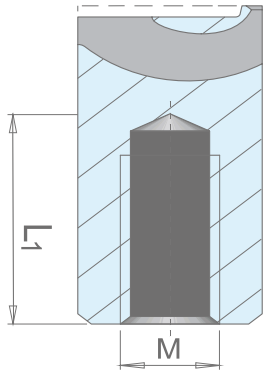
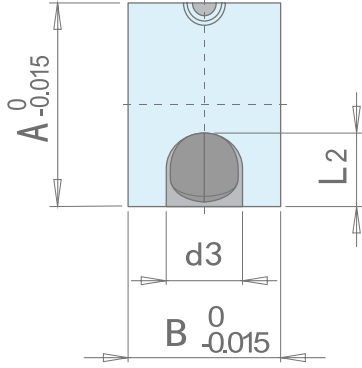

Takkeli modelleri belirtir.

Sip. No.	A	B	d1	d2	d3	h1	L1	L2	M
HGS0806S2S1	8	6	0.6	1.9	3	0.6	16	3.25	4
HGS0806S2S1			0.8	2.1					
HGS1008S2S1	10	8	0.8	2.2	4	0.8	15	4	5
HGS1010S2S1			1.0	2.3					
HGS1012S2S1			1.2	2.6					
HGS1014S2S1			1.4	2.7					
HGS1016S2S1			1.6	3.0					
HGS1208S2S1	12	10	0.8	2.1	5	0.8	14	5	5
HGS1210S2S1			1.0	2.3					
HGS1212S2S1			1.2	2.6					
HGS1214S2S1			1.4	2.7					
HGS1216S2S1			1.6	3.0					
HGS1218S2S1			1.8	3.1					
HGS1220S2S1			2.0	3.4					
HGS1412S2S1	14	12	1.2	2.5	6	0.8	13	6	6
HGS1414S2S1			1.4	2.7					
HGS1416S2S1			1.6	3.0					
HGS1418S2S1			1.8	3.1					
HGS1420S2S1			2.0	3.4					
HGS1422S2S1			2.2	3.5					
HGS1424S2S1			2.4	3.8					
HGS1428S2S1			2.8	4.2					