

# İTİCİ PİMLER

## KADEMELİ İTİCİ PİM

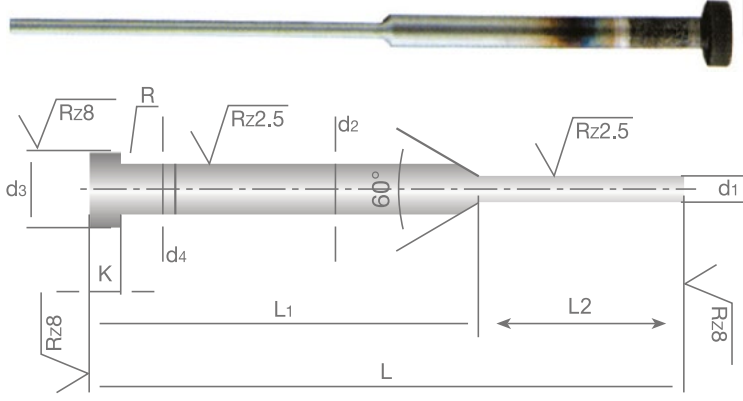

- Malzeme : Özel alaşımlı çelik 1.2516
- Sertlik : 60+2 HRC / Kafa 45+5 HRC
- Yüzey : Sertleştirilmiş, taşlanmış.

Kademeli itici pimler özel ürün olup, aşağıdaki tablo temsilen örnek olarak verilmiştir. İstenilen her ebat ve ölçülerde temin edilebilir. Sürekli stoklarımızda bulunamayabilir.

Sip. No.	d1 (g6)		d2 (g6)	d3 (-0,2)	d4	K (-0,05)	R (+0,2)	L1 (-1)	L (+2)
	Min.	Max.							
KIPHK0.8100	0.8	1.4	2	4		2	0.2	50	100
KIPHK0.8125									125
KIPHK0.8160									160
KIPHK0.8200									200
KIPHK1.5100	1.5	2.4						50	100
KIPHK1.5125									125
KIPHK1.5160									160
KIPHK1.5200									200
KIPHK2.5100	2.5	2.9	3	6		3	0.3	50	100
KIPHK2.5125									125
KIPHK2.5160									160
KIPHK2.5200									200

## BORU İTİCİ PİM (SERTLEŞTİRİLMİŞ)

PLASTİK ENJEKSİYON  
METAL ENJEKSİYON



- Malzeme : Özel alaşımlı çelik 1.2344
- Sertlik : 65+2 HRC / Kafa 45+5 HRC
- Yüzey : Sertleştirilmiş, taşlanmış.

Kademeli ve özel ölçü ürünler de imal edilmektedir.

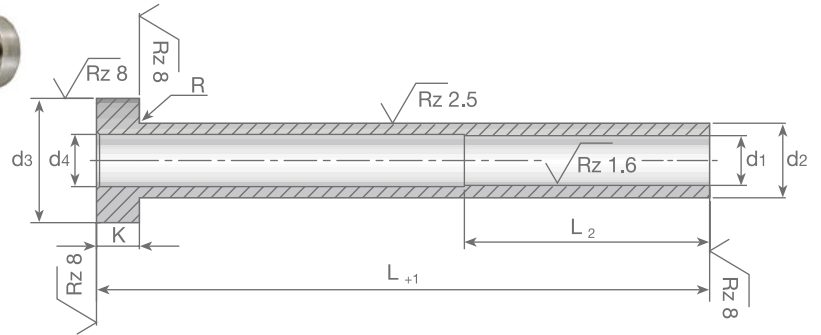

Sip.No.	d1 (H5)	d2 (g6)	d4	d3 (-0,2)	K (-0,05)	R (+0,2)	L2 (+2)	L (+1)
BIPHK2475								75
BIPHK24100								100
BIPHK24125								125
BIPHK24150								150
BIPHK24160								160
BIPHK24175	2	4	2.4	8				175
BIPHK24200								200
BIPHK24225								225
BIPHK24250								250
BIPHK24275								275
BIPHK24300								300
BIPHK2.5575							35	75
BIPHK2.55100								100
BIPHK2.55125					3	0.3		125
BIPHK2.55150								150
BIPHK2.55160								160
BIPHK2.55175	2.5		2.9					175
BIPHK2.55200								200
BIPHK2.55225								225
BIPHK2.55250		5		10				250
BIPHK2.55275								275
BIPHK2.55300								300
BIPHK3575								75
BIPHK35100								100
BIPHK35125	3		3.4				45	125
BIPHK35150								150
BIPHK35160								160

Sip.No.	d1 (H5)	d2 (g6)	d4	d3 (-0,2)	K (-0,05)	R (+0,2)	L2 (+2)	L (+1)
BIPHK35175								175
BIPHK35200								200
BIPHK35225								225
BIPHK35250	3	5	3.4	10	3	0.3	45	250
BIPHK35275								275
BIPHK35300								300
BIPHK35500								500
BIPHK3.5675								75
BIPHK3.56100								100
BIPHK3.56125								125
BIPHK3.56150								150
BIPHK3.56160								160
BIPHK3.56175								175
BIPHK3.56200			6					200
BIPHK3.56225								225
BIPHK3.56250								250
BIPHK3.56275	3.5		3.9	12	5	0.5	45	275
BIPHK3.56300								300
BIPHK3.56500								500
BIPHK3.5775								75
BIPHK3.57100								100
BIPHK3.57125								125
BIPHK3.57150			7					150
BIPHK3.57160								160
BIPHK3.57175								175
BIPHK3.57200								200
BIPHK3.57225								225

# İTİCİ PİMLER

## BORU İTİCİ PİM (SERTLEŞTİRİLMİŞ)

PLASTİK ENJEKSİYON  
METAL ENJEKSİYON



- Malzeme : Özel alaşımlı çelik 1.2344
- Sertlik : 65+2 HRC / Kafa 45+5 HRC
- Yüzey : Sertleştirilmiş, taşlanmış.

Kademeli ve özel ölçü ürünler de imal edilmektedir.

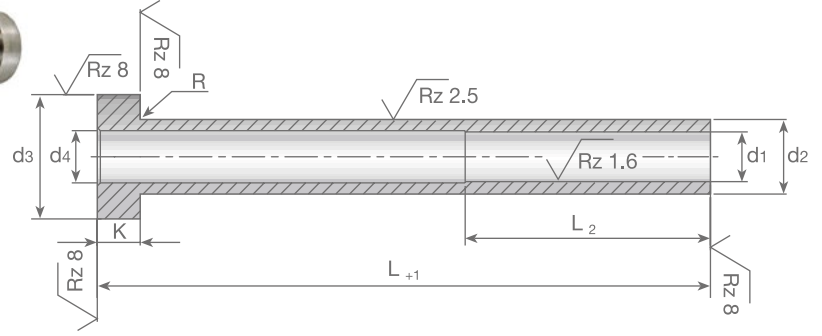

Sip.No.	d1 (H5)	d2 (g6)	d4	d3 (-0,2)	K (-0,05)	R (+0,2)	L2 (+2)	L (+1)			
BIPHK3.57250	3.5	7	3.9	12	5	0.5	45	250			
BIPHK3.57275								275			
BIPHK3.57300								300			
BIPHK3.57500								500			
BIPHK4675	4	6	4.4					14	5	0.5	75
BIPHK46100											100
BIPHK46125											125
BIPHK46150											150
BIPHK46160											160
BIPHK46175											175
BIPHK46200											200
BIPHK46225											225
BIPHK46250				250							
BIPHK46275				275							
BIPHK46300				300							
BIPHK46500				500							
BIPHK4.2875	4.2	8	4.6	14	5	0.5	45	75			
BIPHK4.28100								100			
BIPHK4.28125								125			
BIPHK4.28150								150			
BIPHK4.28160								160			
BIPHK4.28175								175			
BIPHK4.28200								200			
BIPHK4.28225								225			
BIPHK4.28250								250			
BIPHK4.28275								275			
BIPHK4.28300								300			
BIPHK4.28500								500			
BIPHK5875	5	8	5.4	14	5	0.5	45	75			
BIPHK58100								100			
BIPHK58125								125			
BIPHK58150								150			
BIPHK58160								160			
BIPHK58175								175			
BIPHK58200								200			
BIPHK58225								225			
BIPHK58250								250			
BIPHK58275								275			
BIPHK58300								300			
BIPHK58500								500			
BIPHK61075	6	10	6.4	16	5	0.5	45	75			
BIPHK610100								100			
BIPHK610125								125			
BIPHK610150								150			

Sip.No.	d1 (H5)	d2 (g6)	d4	d3 (-0,2)	K (-0,05)	R (+0,2)	L2 (+2)	L (+1)						
BIPHK610160	6	10	6.4	16	5	0.5	45	160						
BIPHK610175								175						
BIPHK610200								200						
BIPHK610225								225						
BIPHK610250								250						
BIPHK610275								275						
BIPHK610300								300						
BIPHK610500								500						
BIPHK81275								8	12	8.4	20	7	0.7	75
BIPHK812100														100
BIPHK812125														125
BIPHK812150														150
BIPHK812160	160													
BIPHK812175	175													
BIPHK812200	200													
BIPHK812225	225													
BIPHK812250	250													
BIPHK812275	275													
BIPHK812300	300													
BIPHK812500	500													
BIPHK101475	10	14	10.4	22	7	0.7	75							
BIPHK1014100							100							
BIPHK1014125							125							
BIPHK1014150							150							
BIPHK1014160							160							
BIPHK1014175							175							
BIPHK1014200							200							
BIPHK1014225							225							
BIPHK1014250							250							
BIPHK1014275							275							
BIPHK1014300							300							
BIPHK1014500							500							
BIPHK121675	12	16	12.4	22	7	0.7	75							
BIPHK1216100							100							
BIPHK1216125							125							
BIPHK1216150							150							
BIPHK1216160							160							
BIPHK1216175							175							
BIPHK1216200							200							
BIPHK1216225							225							
BIPHK1216250							250							
BIPHK1216275							275							
BIPHK1216300							300							
BIPHK1216500							500							