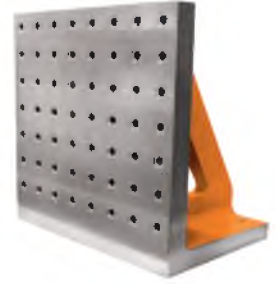

Referans Nr.	a	b	c	d	e	f	g	h	Ø1	j	k	s	s1	
2570-30012	300	300	220	100	250	90	40	30	18	M12	75	25	170	50
2570-40012	400	400	280	160	320	90	40	30	18	M12	75	30	240	88
2570-50012	500	500	345	200	400	90	50	35	18	M12	75	35	300	175
2570-63012	630	630	435	250	500	100	50	40	18	M12	105	40	360	298
2570-30016	300	300	220	100	250	90	40	30	18	M16	75	25	170	45
2570-40016	400	400	280	160	320	90	40	30	18	M16	75	30	240	84
2570-50016	500	500	345	200	400	90	50	35	18	M16	75	35	300	170
2570-63016	630	630	435	250	500	100	50	40	18	M16	105	40	360	293

Ürün Nr. 2570 L Gönye Delikli

- Malzeme GG 26 DIN normalize edilmiştir.
- CNC yatay ve diik işleme tezgahlarında kullanılır.
- Standart bağlama ekipmanlarına uyumludur.
- Yüzeyinde M12 - M16 diiş merkez aralıđı 50 ± 0.02
- Talebe göre çelik burçlu diişleri sertleştirilmiştir.

Product Nr. 2570 L Setsquare with Hole

- Material is normalized as GG 26 DIN.
- It is used in CNC Horizontal end Vertical processing benches.
- It is in compliance with Standard Coupling Equipment.
- M12 - M16 thread gap on it's surface is 50 ± 0.02.
- According to the demand, it's steel bush threads are hardened.

Not: Çelik burçlu

Referans Nr. 2575

Note: Steel bush

Reference No. 2575

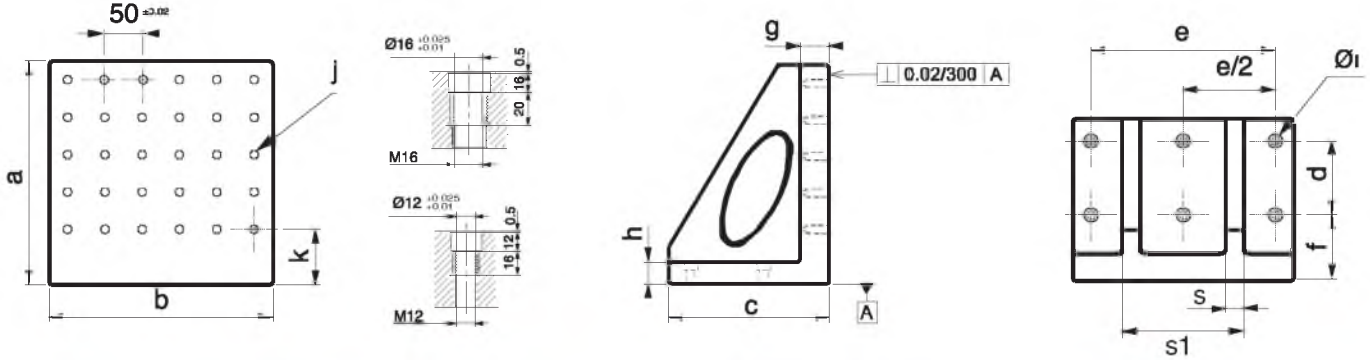

Referans Nr.	a	b	c	d	e	f	g	h	Ø1	j	k	L	s	s1	
2590-30014	300	300	220	100	250	90	60	30	18	14	100	50	25	170	50
2590-40014	400	400	300	160	320	90	60	30	18	14	100	50	30	240	100
2590-50014	500	500	350	200	400	90	60	35	18	14	100	50	35	300	185
2590-63014	630	630	450	250	500	100	65	40	18	14	125	65	40	360	315
2590-30018	300	300	220	100	250	90	60	30	18	18	100	50	25	170	50
2590-40018	400	400	300	160	320	90	60	30	18	18	100	50	30	240	98
2590-50018	500	500	350	200	400	90	60	35	18	18	100	50	35	300	174
2590-63018	630	630	450	250	500	100	65	40	18	18	125	65	40	360	286

Ürün Nr. 2590 L Gönye "T" Kanallı

- Malzeme GG 26 DIN normalize edilmiştir.
- CNC yatay ve diik işleme tezgahlarında kullanılır.
- Standart bağlama ekipmanlarına uyumludur.
- "T" kanal ölçüleri 14mm - 18mm DIN 650 standartındadır.

Product Nr. 2590 L Setsquare "T" Slot

- Material is normalized as GG 26 DIN.
- It is used in CNC Horizontal end Vertical processing benches.
- It is in compliance with Standard Coupling Equipment.
- "T" Slot is in the standard of 14mm - 18mm DIN 650.

