

Referans Nr.	L	ı	f	n	b	k	c	e	s	Ø16H7 j	Ø16H7 j1	kg
2450-415L	503.5	415	45	-	125	35	31	30	72	100	100	29.25
2450-615L	703.5	615	50	-	160	35	31	30	90	100	300	46.75

Ürün Nr. 2450 Divizör Kulesi (Dikdörtgen)

- Divizör kulesi dik işleme tezgahlarında divizöre bağlanarak, dördüncü eksen 360 derece kullanma imkanı sağlar.
- Divizör kulesi üzerine iş parçası direk bağlanabildiği gibi, mengene grupları veya farklı aparatlarda kullanılır.
- Malzeme GG 26 DIN Normalize edilmiştir.

Product Nr. 2450 Index Table Turret (Rectangular)

- Index Table Turret is connected to the index table of vertical machining benches and this application provides the possibility to use the fourth axis in 360 degrees.
- Workpiece taking place on the Index Table Turret can be applied directly and at the same time it can be used in vice groups and with different apparatuses.
- Material is normalized as GG 26 DIN.

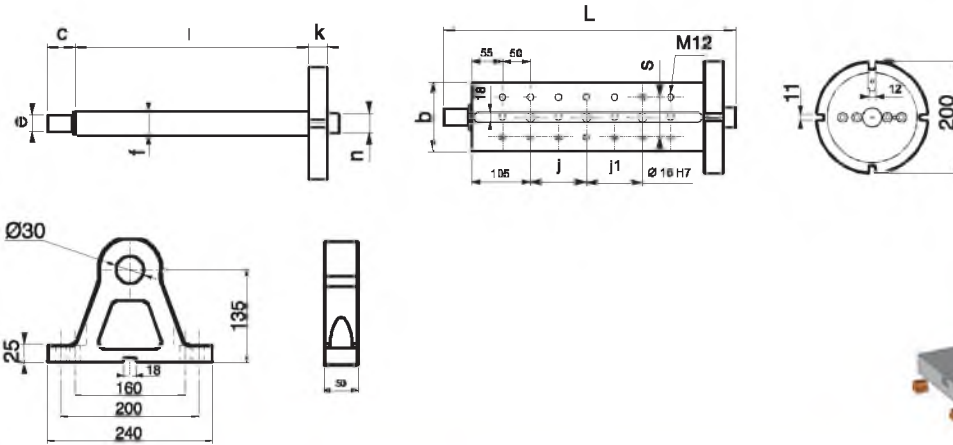

Yatak= Nr.2460

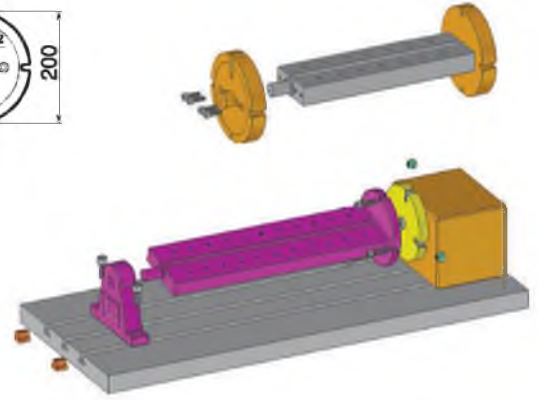

Referans Nr.	L	ı	n	k	e	c	Ø16H7 j	Ø16H7 j1	kg
2470-415K	502	415	-	35	30	31	100	100	33
2470-615K	702	615	-	35	30	31	100	300	42

Ürün Nr. 2470 Divizör Kulesi (Kare)

- Divizör kulesi dik işleme tezgahlarında divizöre bağlanarak, dördüncü eksen 360 derece kullanma imkanı sağlar.
- Divizör kulesi üzerine iş parçası direk bağlanabildiği gibi, mengene grupları veya farklı aparatlarda kullanılır.
- Malzeme GG 26 DIN Normalize edilmiştir.

Product Nr. 2470 Index Table Turret (Square)

- Index Table Turret is connected to the index table of vertical machining benches and this application provides the possibility to use the fourth axis with 360 degrees.
- Workpiece taking place on the Index Table Turret can be applied directly and at the same time it can be used in vice groups and with different apparatuses.
- Material is normalized as GG 26 DIN.

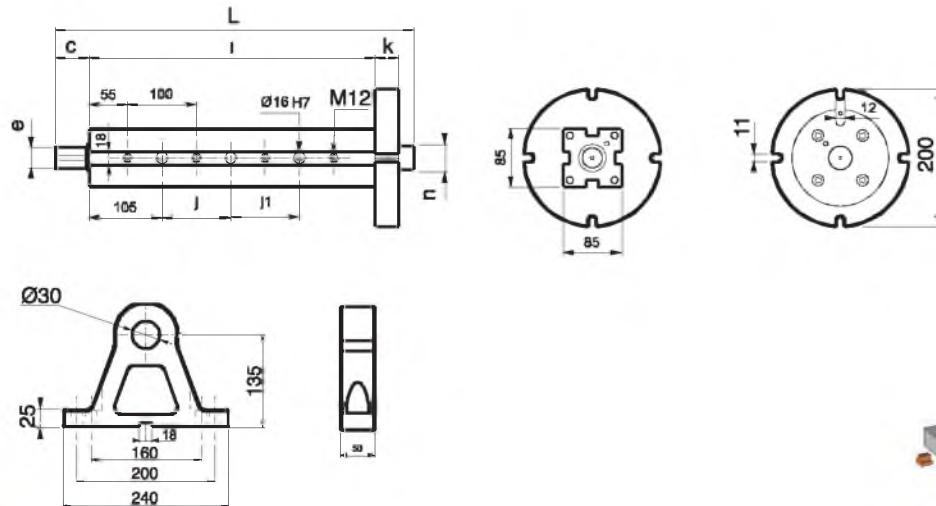

Yatak= Nr.2460

