

Referans Nr.	J x M	k	h	h1	e	L	L1	L2	
2390-010	ISO30-M12	83	99	35	18	95	128	26	6030
2390-015	ISO40-M16								6555
2390-020	ISO50-M24								9110
2390-025	BT40 - M16								6900
2390-030	BT50 - M24								9840
2390-035	SK40- M16								6750
2390-040	SK50- M24					8970			
2390-040	MK4 - M16					132	6180		
2390-050	MK4 Kamalı					6880			
2390-050	MK5 - M20					7785			
2390-060	MK5 Kamalı					7450			

Ürün Nr. 2390 Delik İşleme Aparatı

- Ürün 0.02 işleme hassasiyetli olup 18mm'den 210mm'ye kadar işlem yapabilir.
- Modüler sistem oluşu kullanım için kolaylık sağlar.
- Tutucu değiştirilerek CNC ve Mekanik tezgahlarda kullanım avantajı sağlar.
- Ürün, 4 ad. delik barası, 1 ad. "T" kanal temizleyici ile ahşap kutudadır.
- Değiştirilebilir Tutucular:
- ISO-30-40-50 BT40-50 SK40-50 MK4-5 ile kullanım imkanı..

Product Nr. 2390 Hole Machining Apparatus

- Product has 0.02 machining sensitivity and it can implement processes from 18mm to 210mm.
- It's modular system structure provides convenience in using.
- It provides the possibility of using in CNC and Mechanical benches by changing the holder.
- The product takes place in a wooden box with it's 4 hole bar, 1 "T" slot scraper.
- Changeable Holders:
- Possibility to be used with ISO30-40-50 BT 40-50 SK40-50 MK4-5.



Modülerdir, sabitleme işlemi saat yönüne doğru vidalanarak yapılır.
It is modular. Fixing process is done screwing towards clockwise



Referans Nr.	L	L1	e	Kesici uç tipi Cutting Edge type	
2395-1	85	-	18	DCMT	112
2395-2	95	-	18	DCMT	130
2395-3	132	-	18	DCMT	200
2395-4	-	128	18	-	360

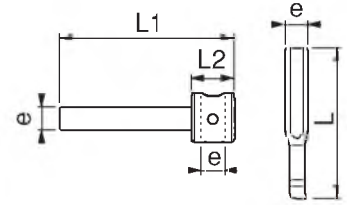
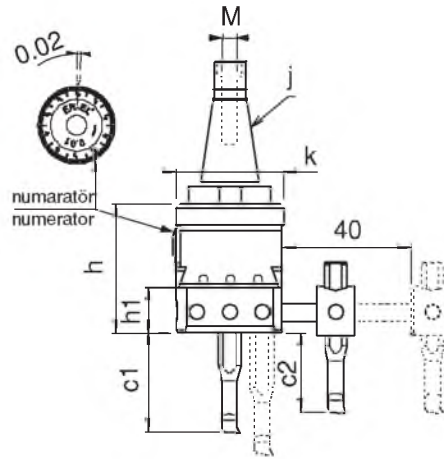

min	Ø	max	c1	devir dk. Revolution per minute
18		95	50	400-450
18		95	63	400-450
20		100	100	170-220

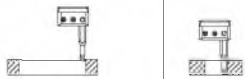

- Ürünün kazağındaki alt deliklerine baraları takarak 18mm'den 100mm çapa kadar büyütme 0-100mm kadar derinliğe inebilir.
- It is possible to have enlargement from 18mm to 100mm by attaching bars to the bottom holes taking place in the slide of the product and it can go down to depth up to 0-100mm.



min	Ø	max	c2	devir dk. Revolution per minute
95		210	55	90-170
95		210	65	90-170

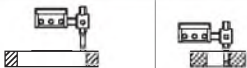

- Ürünün kazağındaki yan deliğe ara vasatı takarak, şekilde görüldüğü gibi 95mm'den - 210mm çapa kadar büyütme, 0-65mm kadar derinliğe inebilir
- By applying intermediary means to the side hole of the product's slide, it is possible to have enlargement from 95mm to 210mm and it can go down to depth up to 0-65mm as seen in the figure.

