

Referans Nr.	A min-max	Strok	Bar	Sıkma kuvveti Clamping force kgf	 (kg)
2305-0251	0 - 251	13 x 2	30	750	15.2
			40	1000	
			50	1250	
			60	1500	



Ürün Nr. 2305 Hidrolik Çift Açılır Mengene

- Ürün işlem yapılacak malzemeyi sabitleirken aynı zamanda da merkezleme yapmaktadır. Bu sistemin avantajı özellikle dış çap ölçüleri değişken malzemelerde merkez değişmeden işlem yapılabilir. Diğer özelliği ise yumuşak çenelere işlenecek parçanın formu uygulanabilir (1-2-3-4 şekillerde görüldüğü gibi.)
- Hareketli yüzeylerin tamamı hassas taşlanmış
- Sistem hidrolik çalışır
- Yağ giriş - Yağ dönüş
- Siyah Kaplama

Product Nr. 2305 Hydraulic Centering Vice

- This product fixes the material to be processes and at the same time it makes centering. The advantage of this system specially shows itself when making machinings of the materials having different outer diameter measurements as it implements this process without changing the center. It's other characteristic is to apply the form of the piece to be machined with soft claws (as seen in Figures: 1-2-3-4-5 and 6).
- Entire moving surface is sensitively grinded
- Hydraulic system works
- Oil inlet - Oil outlet
- Black coating

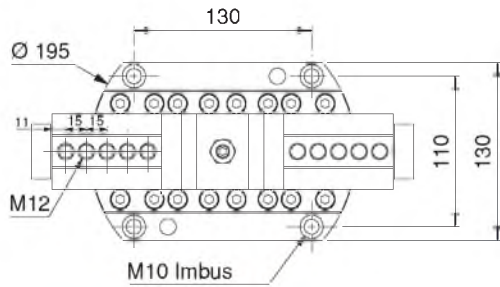
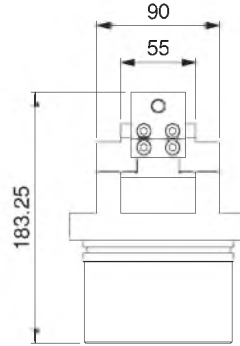
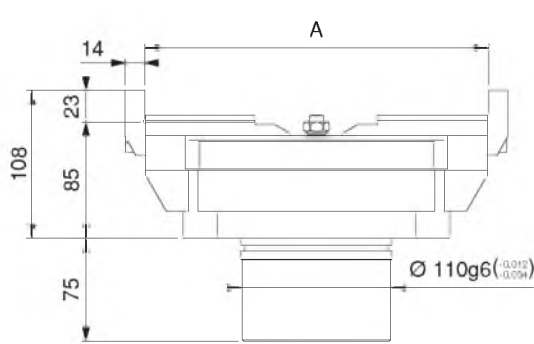

Şekil Figure 1



Şekil Figure 2



Şekil Figure 3



Şekil Figure 4

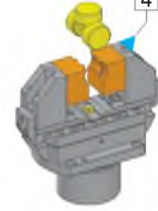

Referans Nr.	A min-max	Strok	Bar	Sıkma kuvveti Clamping force kgf	 (kg)
2307-0188	0-188	8.5x2	6	750	18.5

Pnömatik Çift Açılır Mengene

Pneumatic Centering Vice



Ürün Nr. 2307 Pnömatik Çift Açılır Mengene

- Sistem pnömatik çalışır.

Product Nr. 2307 Pneumatic Centering Vice

- Pneumatic system works

