

Referans Nr.	L	h	a	a1	b	b1	sw	 (g)
2295-090	90	39	55	73	7	21-35	8	1480
2295-115	115	49	65	82.5	8.5	31-42	10	2690
2295-130	130	56	75	98	10	37-48	12	4160



Ürün Nr. 2295 CNC 5 Eksen Parça Bağlama Aparatı

- İş parçasına kılavuz yuva açılarak aparata bağlanır.
- Malzeme Ck45 DIN
- Sertlik 32-35 HRC
- Siyah kaplama

Product Nr. 2295 CNC 5 Axis Clamping Parts Apparatus

- Apparatus is connected at workpiece, swallow nest opening.
- Material: Ck45 DIN
- Hardness: 32-35 HRC
- Black coating

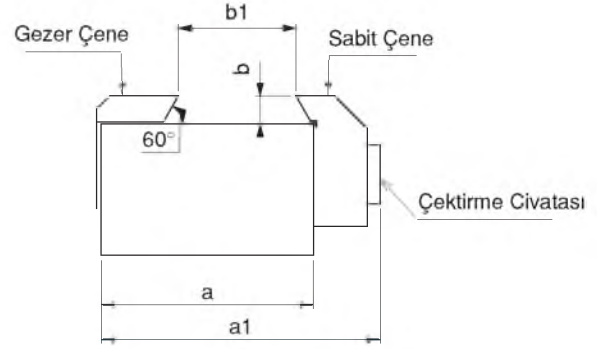
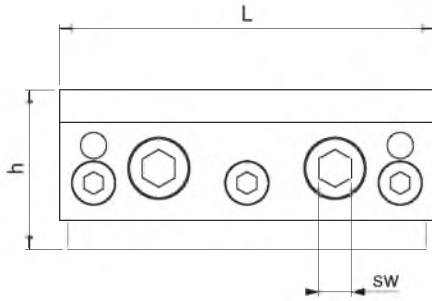

CNC 5 Eksen Parça Bağlama Takozu

CNC 5 Axis Clamping Parts Wedge

Referans Nr.	a	h	L	d	 (g)
2297-090	55	58	87	M10	2110
2297-115	65	68	110	M12	3750
2297-130	75	80	126.6	M12	5830

Ürün Nr. 2297 CNC 5 Eksen Parça Bağlama Takozu

- Malzeme Ck45 DIN
- Sertlik 32-35 HRC
- Siyah kaplama

Product Nr. 2297 CNC 5 Axis Clamping Parts Wedge

- Material: Ck45 DIN
- Hardness: 32-35 HRC
- Black coating

