

Referans Nr.	H min.	H max.	D1	Ø12x50 H1 min.- H1 max.	Ø12x80 H1 min.- H1 max.	↓ Kgf	⚖ (g)
1515-065085	65	85	50	93-113	123-143	3000	810
1515-085125	85	125	50	113-153	143-183	3000	1050

Ürün Nr. 1515 Manyetik Vidalı Yükseltici

- Ürün manyetik olduğundan dolayı kendi ağırlığını taşıdığı için yatay bağlamalarda özellikle enjeksiyon makinelerinde kullanım avantajı sağlar.
- Malzeme: Ck45 DIN
- Sertlik: 35-38 HRC
- Siyah kaplama

Product Nr. 1515 Magnetic Screw Booster

- Because of magnetic it holds its own weight. Therefore it provides using advantage in horizontal clamping especially on injection machines.
- Material: Ck45 DIN
- Hardness: 35-38 HRC
- Black coating

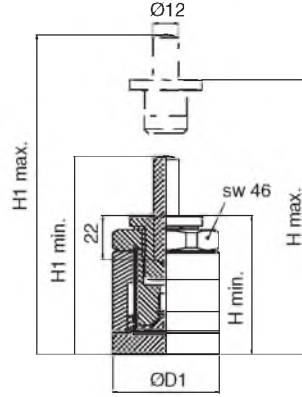

Modüler Manyetik Yükseltici

Modular Magnetic Booster

Referans Nr.	H min-max. A	H min-max. B	TR	d1	d2	d3	↓ kgf	⚖ (g)
1517-04262	42-52	52-62	30x4	50	50	53.5	6000	700
1517-05080	50-70	60-80	30x4	50	50	53.5	6000	770
1517-70110	70-100	80-110	30x4	50	50	53.5	6000	1050

Ürün Nr. 1517 Modüler Manyetik Yükseltici

- Malzeme: Ck45 DIN
- Siyah Kaplama

Product Nr. 1517 Modular Magnetic Booster

- Material: Ck45 DIN
- Black coating

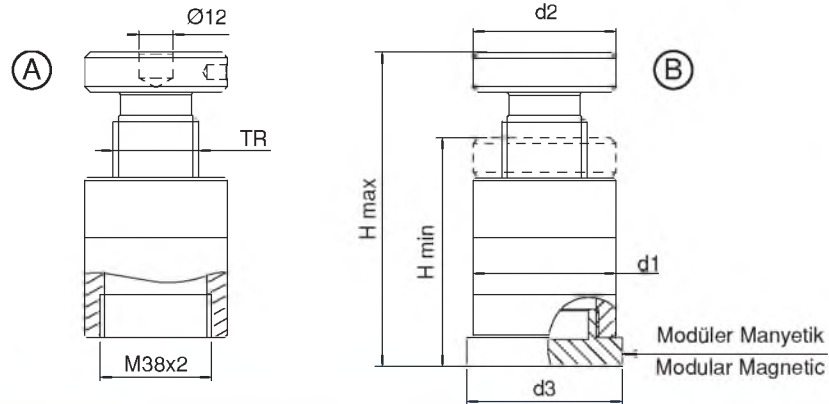

Referans Nr.	H min.	H max.	b1	b2	L	sw	↑ kgf	⚖ (g)
1520-050063	50	63	-	40	63	8	4000	1890
1520-100125	100	125	115	60	125	14	10000	9910
1520-170190	170	190	145	80	175	22	25000	28480

Ürün Nr. 1520 Blok Destek

- Ürün Özellikle ağır parçaların desteklenmesi ve kaldırılması için tasarlanmıştır.
- Malzeme: Ck45 DIN
- Sertlik: 35-38 HRC
- Siyah kaplama

Product Nr. 1520 Support Block

- Designed for supporting and lifting of heavy work pieces
- Material: Ck45 DIN
- Hardness: 35-38 HRC
- Black coating

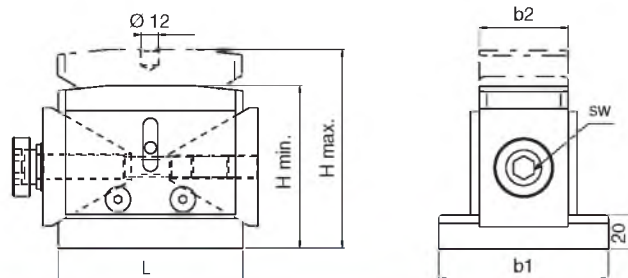

Blok Destek

Support Block

