

Referans Nr.	Sıkma Yüksekliği Clamping Height				Sıkma Torku Clamping Stroke	L2	L5	W	L	H4	d	P	H	L1	L3	W1
	Finiş Yüzey Temas Finished Surface Contact		Kaba Yüzey Temas Rough Surface Contact													
	Min.	Max.	Min.	Max.												
1483-03240	32 (32-29.5)	40 (40-37.5)	35 (35-32.5)	43 (43-40.5)	2.5	20	11	42	18	8	5.5	32	81	25.5	25	26
1483-03748	37 (37-33.5)	48 (48-44.5)	42 (42-38.5)	53 (53-49.5)	3.5	25	14	52	22	10	6.6	40	100	32	31	32

Referans Nr.	W2	H2	H1	M	H3	R	H5	L4	Ayarlanabilir Kol Adjustable Handles	İzin Verilen Yük (N) Allowable Operating Load (N)	Sıkma Kuvveti Clamping Force Kgf	Sıkma Mekanizması Clamping Mechanism	(g)
1483-03240	22	10	45	M6	24	40	47	16	FKF8-BR	170	240	Vida Screw	242
1483-03748	28	12	55	M8	30.5	65	63	20	FKF8-BR	210	420	Vida Screw	490

### Ürün Nr. 1483 Tek Dokunuş Üstten Bağlama

#### Gövde

- Malzeme: Ck45 DIN
- Sertlik: 28-32 HRC
- Siyah Kaplama

#### Sıkma Pabucu

- Malzeme: 42 CrMo 4 DIN
- Sertlik: 38-42 HRC
- Siyah Kaplama

### Product Nr. 1483 One-Touch Above Clamping

#### Body

- Material: Ck45 DIN
- Hardness: 28-32 HRC
- Black coated

#### Clamping Arm

- Material: 42 CrMo 4 DIN
- Hardness: 38-42 HRC
- Black coated

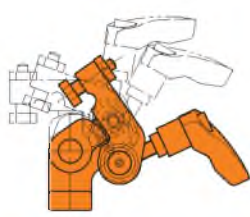
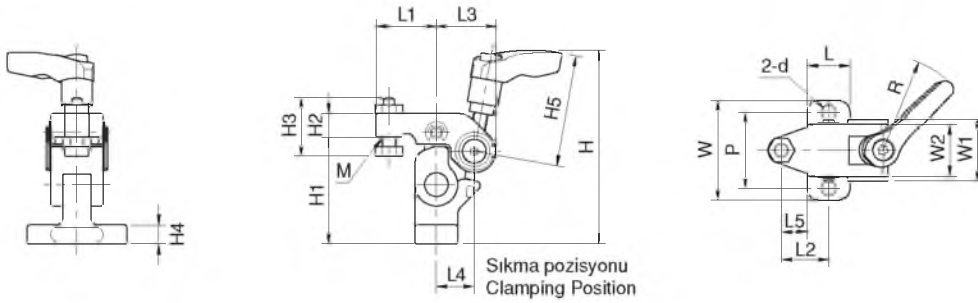

Açık Pozisyon  
Unclamped

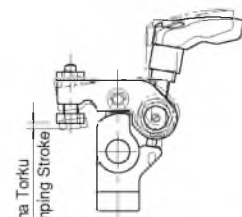
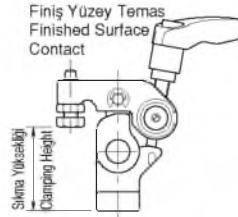

### Kullanım Şekli / How To Use

