

Referans Nr.	a	m	h		s	s1	e1	d	sw	L	e	b	c	Sıkma Kuvveti Clamping Force Kgf	Scales (g)
			min	max											
1130-014 T	14	M12	0	60	15-83	30	113	M18	10	130	39	48	16	2000	3040
1130-016 T	16	M12	0	60	15-83	30	113	M18	10	130	39	48	16	2000	3055
1130-018 T	18	M12	0	60	15-83	30	113	M18	10	130	39	48	16	2000	3085
1130-020 T	20	M12	0	60	15-83	30	113	M18	10	130	39	48	16	2000	3135
1130-022 T	22	M12	0	60	15-83	30	113	M18	10	130	39	48	16	2000	3150
1150-118 T	18	M16	0	62	18-96	35	125	M20	12	140	43	55	18	2500	4410
1150-120 T	20	M16	0	62	18-96	35	125	M20	12	140	43	55	18	2500	4460
1150-122 T	22	M16	0	62	18-96	35	125	M20	12	140	43	55	18	2500	4515
1150-124 T	24	M16	0	62	18-96	35	125	M20	12	140	43	55	18	2500	4620
1150-128 T	28	M16	0	62	18-96	35	125	M20	12	140	43	55	18	2500	4725
1160-222 T	22	M20	20	80	22-95	41.5	175	M24	12	24	178	55	74	5500	9030
1160-224 T	24	M20	20	80	22-95	41.5	175	M24	12	24	178	55	74	5500	9120
1160-228 T	28	M24	20	80	22-95	41.5	175	M24	12	24	178	55	74	5500	9180
1160-236 T	36	M24	20	80	22-95	41.5	175	M24	12	24	178	55	74	5500	9600

#### Ürün Nr. 1130-1150-1160 Kızaklı Kombine Bağlama Pabucu (K.K.S.P)

• **1130 Nr. K.K.S.P** (a) 14-22 "T" kanalda M12 imbus civata DIN 508 "T" pabuçla kullanılır. Parça yükseklik sıkma aralığı 0-60mm ileri-geri hareket mesafesi 68mm'dir. Sıkma Kuvveti 2000 kgf.

• **1150 Nr. K.K.S.P** (a) 18-28 "T" kanalda M16 imbus civata DIN 508 "T" pabuçla kullanılır. Parça yükseklik sıkma aralığı 0-62mm ileri-geri hareket mesafesi 78mm'dir. Sıkma Kuvveti 2500 kgf.

• **1160 Nr. K.K.S.P** (a) 22-36 "T" kanalda M20-M24 imbus civata DIN 508 "T" pabuçla kullanılır. Parça yükseklik sıkma aralığı 20-80mm ileri-geri hareket mesafesi 73mm'dir. Sıkma Kuvveti 5500 kgf.

#### Product Nr. 1130-1150-1160 Combined Sliding Clamp (K.K.S.P)

• **1130 Nr. K.K.S.P** (a) 14-22 is used in "T" Slot and M12 imbus bolt is used with DIN 508 "T" clamp. Height clamping gap of the piece is 0-60mm, back-and- forth movement distance is 68mm. Clamping force is 2000 kgf.

• **1150 Nr. K.K.S.P** (a) 18-28 is used in "T" Slot and M16 imbus bolt is used with DIN 508 "T" clamp. Height clamping gap of the piece is 0-62mm, back-and- forth movement distance is 78mm. Clamping force is 2500 kgf.

• **1160 Nr. K.K.S.P** (a) 22-36 is used in "T" Slot and M20-M24 imbus bolt is used with DIN 508 "T" clamp. Height clamping gap of the piece is 20-80mm, back-and- forth movement distance is 73mm. Clamping force is 5500 kgf.

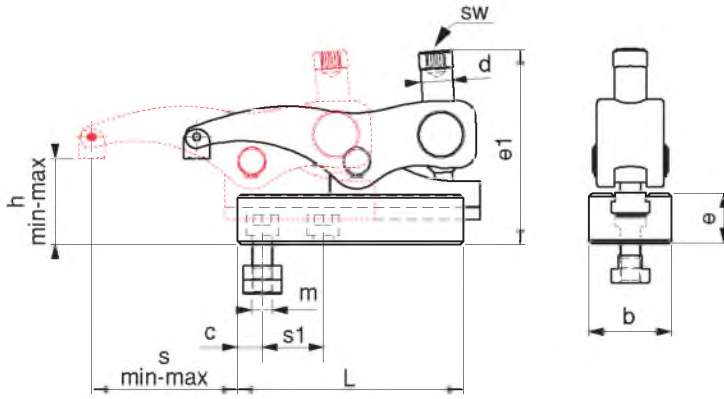

#### UYGULAMA:

- 1- Alt kazağı iş parçasına uygun şekle getir sabitle
- 2- Üst gövdeyi kazağa sür, istenilen pozisyona getir
- 3- Pabuç imbus civatasıyla iş parçasını sabitle
- 4- Parça işlenmek için hazır

#### APPLICATION:

- 1- Slide cradle is brought to suitable form with the work piece and then it is fixed
- 2- Upper body is driven to the slide and it is brought to desired position
- 3- Work piece is fixed with the imbus bolt of the clamp
- 4- Then the work piece becomes ready to be machined.

#### Kullanım Alanı

Enjeksiyon makineleri presler, freze tezgahları, matkap tezgahları ve çeşitli sanayi makineleri

#### Area of Use

Injection Machines, Presses, Milling Machines, Drilling Machines and various Industrial Machines

