

DİŞLİ MİKROMETRESİ

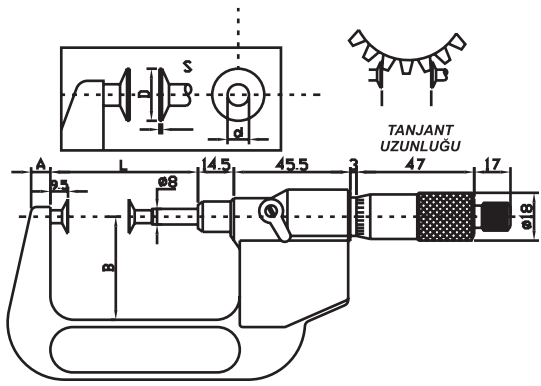

ÖZELLİKLER

- MEKANİK MODELLER DÖNER ÇUBUKLUDUR
- MANDAL KİLİTLİDİR
- DİSK ÇAPI 20 mm
- 0-25 mm DIŞINDA MASTAR ÇUBUKLU

KOD	KAPASİTE	ÖLÇEK	HASSASİYET	A (mm)	B (mm)	L (mm)	D (mm)	S (mm)	d (mm)	FİYAT KODU
AS-141-01-0	0-25 mm	0,01 mm	±0,005 mm	8	32	43	20	0,7	8	13118
AS-141-02-0	25-50 mm	0,01 mm	±0,005 mm	8	44,5	68	20	0,7	8	13119
AS-141-03-0	50-75 mm	0,01 mm	±0,006 mm	8	57	93	20	0,7	8	13120
AS-141-04-0	75-100 mm	0,01 mm	±0,006 mm	10	70	118,5	20	0,7	8	13121

NUMARATÖRLÜ DIŞÇAP MİKROMETRESİ

ÖZELLİKLER

- HIZLI OKUMAYI VE HATA ÖNLEMİYİ SAĞLAYAN MEKANİK NUMARATÖR
- MANDAL KİLİTLİ
- KİLİTLEME VİDASI
- KARBÜR UÇLU ÖLÇÜM YÜZEYLERİ

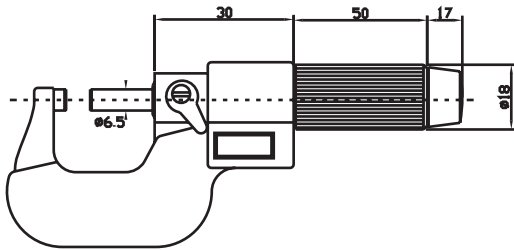

KOD	KAPASİTE	ÖLÇEK	HASSASİYET	FİYAT KODU
AS-108-01-0	0-25 mm	0,01 mm	±0,004 mm	13122

MİKROMETRE STANDI

ÖZELLİKLER

- BU ÜRÜNLER EL MİKROMETRELERİNİN TEZGAH ÜZERİNDE KULLANILMASI İÇİN DİZAYN EDİLMİŞTİR.

KOD	FİYAT KODU
AS-109-02-1	13123



AS-109-02-1

BOYALI ÇELİK GÖVDE