

## MEKANİK DERİNLİK KUMPASI

## ÖZELLİKLER

- TABAN VE ÖLÇÜM YÜZEYLERİ SERTLEŞTİRİLMİŞ VE MİKRO LEPLENMİŞTİR.
- ÜST KİLİTLEME VIDALIDIR

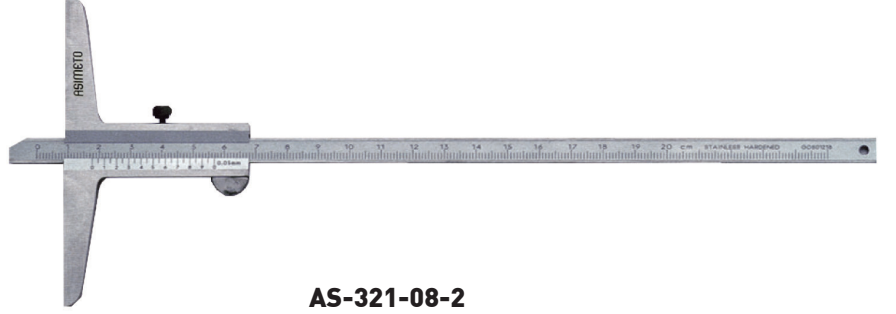
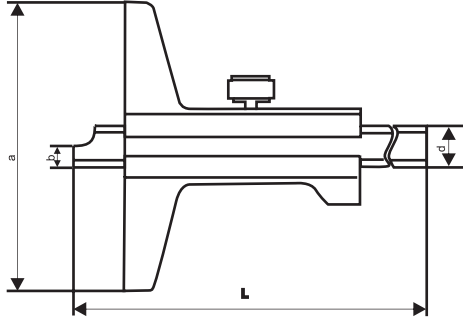

AS-321-08-2

KOD	KAPASİTE	ÖLÇE	HASSASİYET	L (mm)	a (mm)	b (mm)	d (mm)	FİYAT KODU
AS-321-06-2	0-150 mm	0,02 mm	±0,02 mm	250	100	5	10	13067
AS-321-08-2	0-200 mm	0,02 mm	±0,03 mm	300	100	5	10	13068
AS-321-12-2	0-300 mm	0,02 mm	±0,04 mm	400	100	5	10	13069

## DİJİTAL DERİNLİK KUMPASI

## ÖZELLİKLER

- TABAN VE ÖLÇÜM YÜZEYLERİ SERTLEŞTİRİLMİŞ VE MİKRO LEPLENMİŞTİR
- LR44 PİL
- İNÇ/METRİK DÖNÜŞÜMÜ

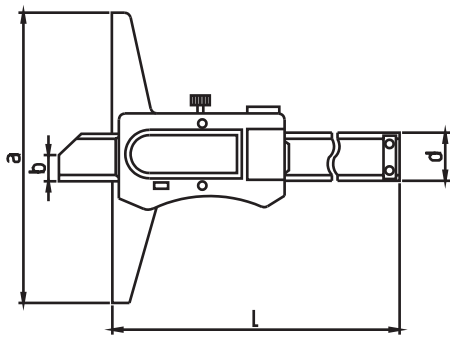

AS-327-06-7

KOD	KAPASİTE	ÖLÇEK	HASSASİYET	L (mm)	a (mm)	b (mm)	d (mm)	FİYAT KODU
AS-327-06-7	0-150 mm	0,01 mm	±0,02 mm	230	100	6	14,5	13070
AS-327-08-7	0-200 mm	0,01 mm	±0,03 mm	280	100	6	14,5	13071
AS-327-12-7	0-300 mm	0,01 mm	±0,04 mm	380	100	6	14,5	13072