

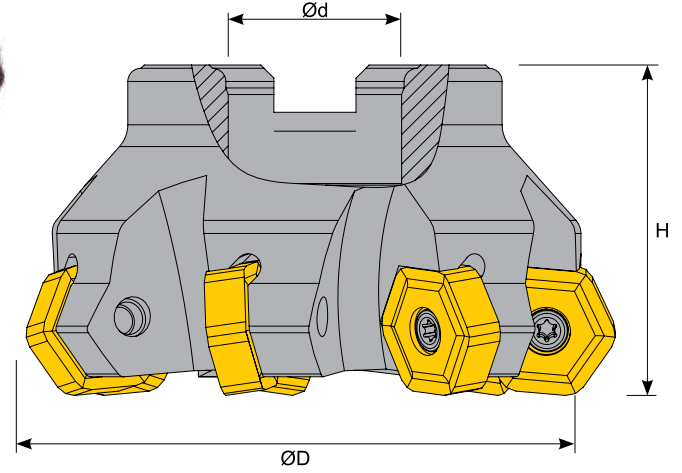



55° HNMX 10

Face Mill

Planmesserkopf



| Sipariş Kodu Order Code Bestell Code | ÜRÜN KODU Product Code Produkt-Code | ÖLÇÜLER (mm) Dimensions (mm) Abmessungen (mm) | | | | KULLANILAN UÇ Insert Wendeplatte | SIKMA ÇİVATASI Clamp Screw Klemmschraube | ANAHTAR Torx Key Torx-Schraubendreher |
|--------------------------------------------|-------------------------------------------|-----------------------------------------------------|----|----|----|--------------------------------------------------------------------------------------|---------------------------------------------------------------------------------------|---------------------------------------------------------------------------------------|
| | | ØD | Ød | Z | H |  |  |  |
| T470 | D063-22 Z05 HN10 | 63 | 22 | 5 | 50 | HNMX 1006 | TC 083 M5 | T20 |
| T472 | D080-27 Z07 HN10 | 80 | 27 | 7 | 50 | | | |
| T474 | D100-32 Z09 HN10 | 100 | 32 | 9 | 62 | | | |
| T476 | D125-40 Z10 HN10 | 125 | 40 | 10 | 62 | | | |
| T478 | D160-40 Z12 HN10 | 160 | 40 | 12 | 62 | | | |

| ÖLÇÜLER (mm) Dimensions (mm) Abmessungen (mm) | |
|-----------------------------------------------------|------|
| L | S |
| 19.10 | 6.30 |

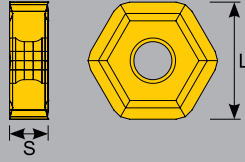

HNMX 1006

